

FP-series TS65B20

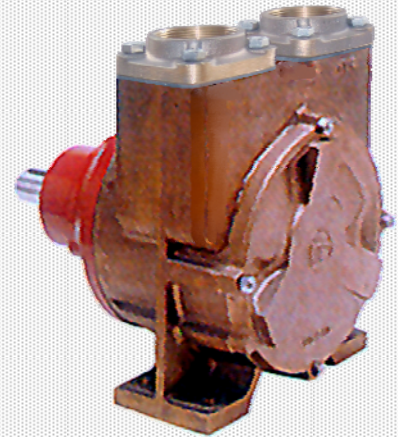

2½" BRONZE SELF-PRIMING SIDE CHANNEL PUMP

- ◆ reliable continuous duty pump
- ◆ corrosion-resistant bronze, with stainless steel shaft
- ◆ self-priming up to 5m
- ◆ flow can be reversed by a simple modification
- ◆ carbon-ceramic mechanical shaft seal

BRONZE PUMPS *for* SEAWATER

Cleghorn Waring
A Division of ITT Industries Ltd
Icknield Way
Letchworth Garden City
Hertfordshire • SG6 1EZ UK

Tel: +44 (0)1462 480380
Fax: +44 (0)1462 482422
mail@cleghorn.co.uk
www.cleghorn.co.uk

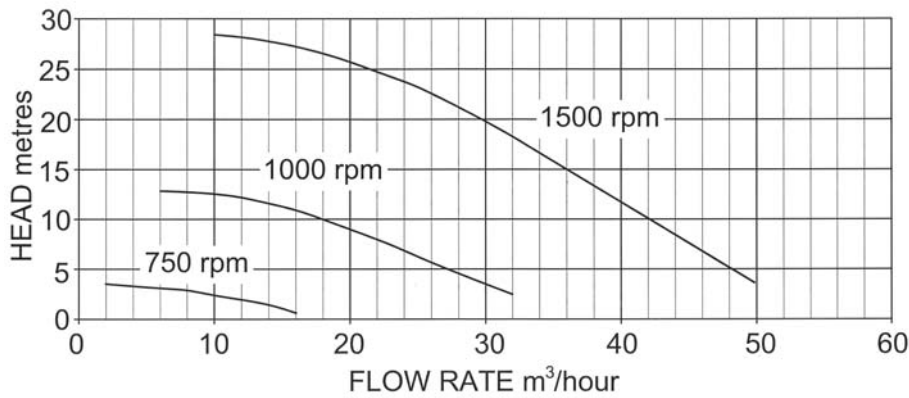

PERFORMANCE

Model	Maximum flow rate			Maximum head	
	l/min	cu.m/hr	gall/min	metres	feet
TS65B20	833	50	183	28	92

Maximum power absorbed 7.5kW at 1500rpm

DIMENSIONS IN MM (APPROX.)

WEIGHT: 48kg

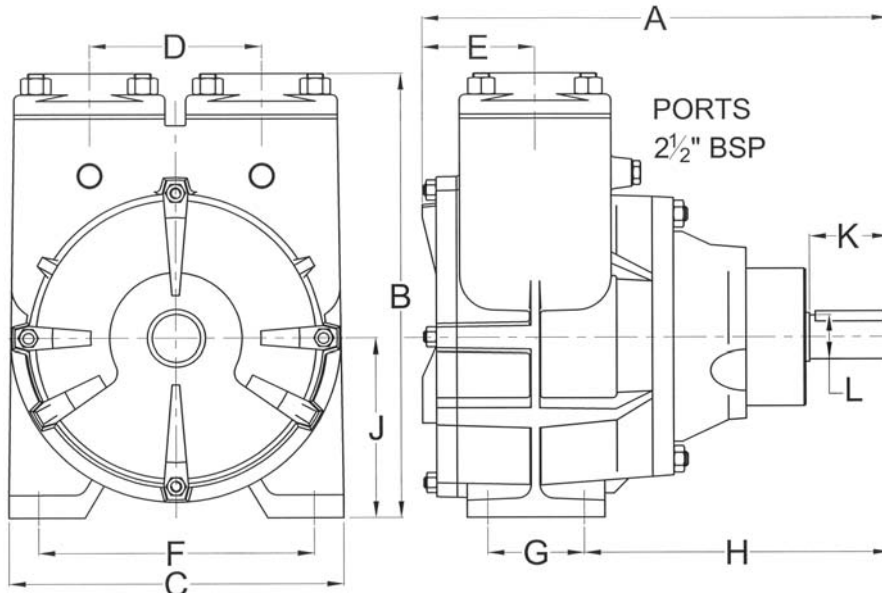

A	B	C	D	E	F	G	H	J	K	L
339	325	243	125	82	200	70	222	132	58	Ø32

MATERIALS OF CONSTRUCTION

Pump casing	bronze
Impeller	bronze
Port counterflanges	bronze
Shaft	stainless steel AISI316
Bearing housing	cast iron
Pump head bolts	stainless steel
O-ring static seal	nitrile rubber

Pump performance and specification are subject to alteration without notice