

FP-series PC25EM2T50

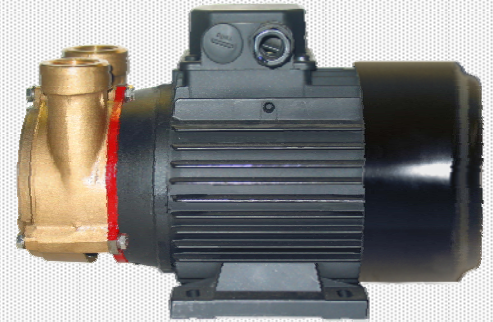

**1" BRONZE
SELF-PRIMING SIDE
CHANNEL PUMP
with
CLOSE COUPLED
AC MOTOR**

- ◆ reliable continuous duty pump
- ◆ corrosion-resistant bronze, with stainless steel shaft
- ◆ self-priming up to 3m
- ◆ carbon-ceramic mechanical shaft seal

**BRONZE
PUMPS
for
SEAWATER**

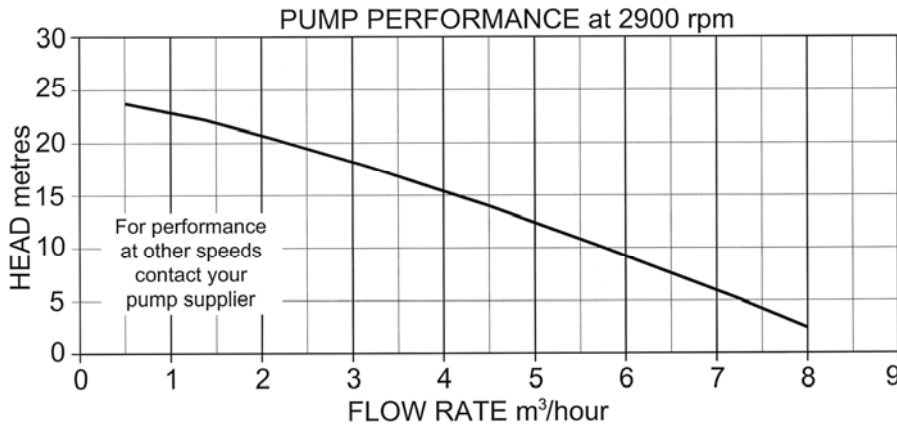

PERFORMANCE

Model	Maximum flow rate			Maximum head	
	l/min	cu.m/hr	gall/min	metres	feet
PC25EM2T50	133	8	29	24	78

Maximum power absorbed 1.1kW at 2900rpm

DIMENSIONS IN MM (APPROX.)

WEIGHT: 11.6kg

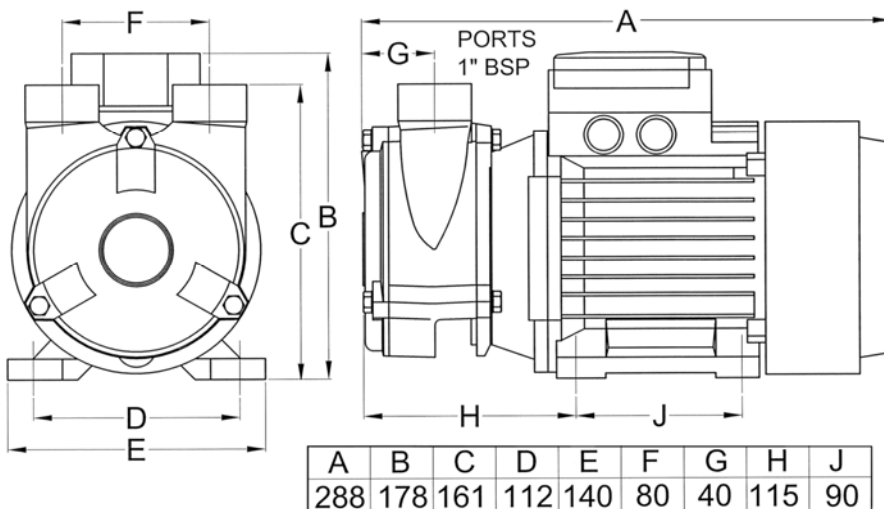

MATERIALS OF CONSTRUCTION

Pump casing	bronze
Impeller	bronze
Shaft	stainless steel AISI316
Bearing housing	cast iron
Pump head bolts	stainless steel
O-ring static seal	nitrile rubber

Pump performance and specification are subject to alteration without notice