

PERFORMANCE:

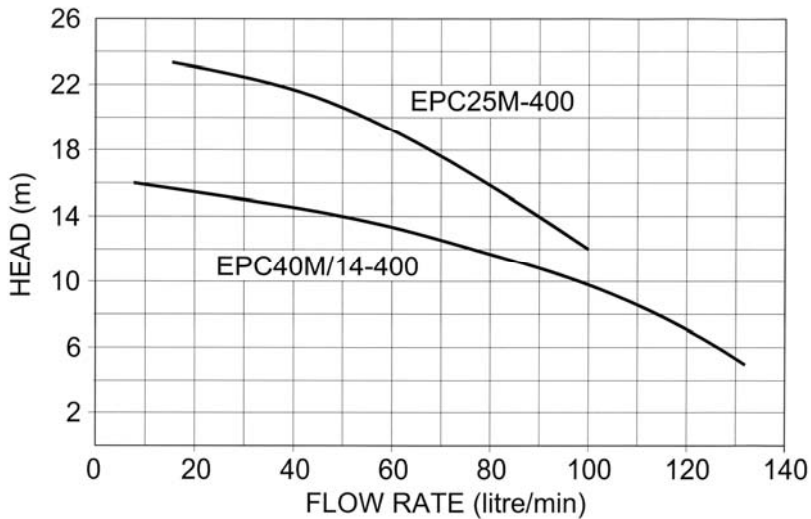

MODEL	POWER kW	RPM
EPC25M	1.1	2900
EPC40M/14	0.75	1400

DIMENSIONS:

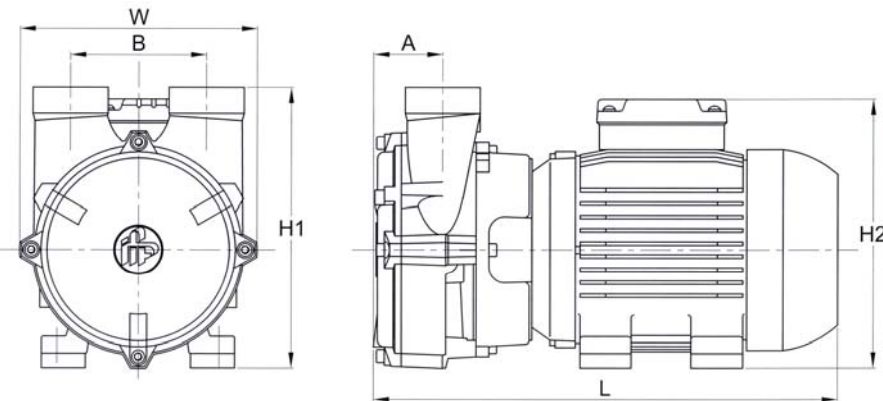

MODEL	H1	H2	L	A	B	W	IN	OUT	weight
EPC25M	167	200	345	40	80	160	1" BSP	1" BSP	17 kg
EPC40M/14	214	220	359	53	105	183	1½" BSP	1½" BSP	20 kg

Dimensions and weight will depend on make and type of motor fitted

MATERIALS OF CONSTRUCTION:

PUMP BODY	Bronze	MOTOR:	
IMPELLER	Bronze	INSULATION	'F' class
SHAFT	Stainless steel AISI316	PROTECTION	TEFV IP55
MECH. SEAL	Carbon-ceramic faces	VOLTAGES	230v/1/50Hz 400v/3/50Hz

GENERAL:

'ECP' series pumps have an outstanding self-priming capability. They are designed for clean liquids, and can handle substantial amounts of entrained air.

EPC-series Self-priming liquid ring PUMPS

In corrosion-resistant
bronze
close coupled to AC
electric motor



- Sea water
- Fresh water supply
- Diesel transfer
- Bilge pumping
- Grey water discharge

...from the specialists

CLEGHORN WARING

Icknield Way • Letchworth
Hertfordshire • SG6 1EZ • UK

tel: +44(0)1462 480380

fax: +44(0)1462 482422

mail@cleghorn.co.uk

www.cleghorn.co.uk