

# FP-series B40

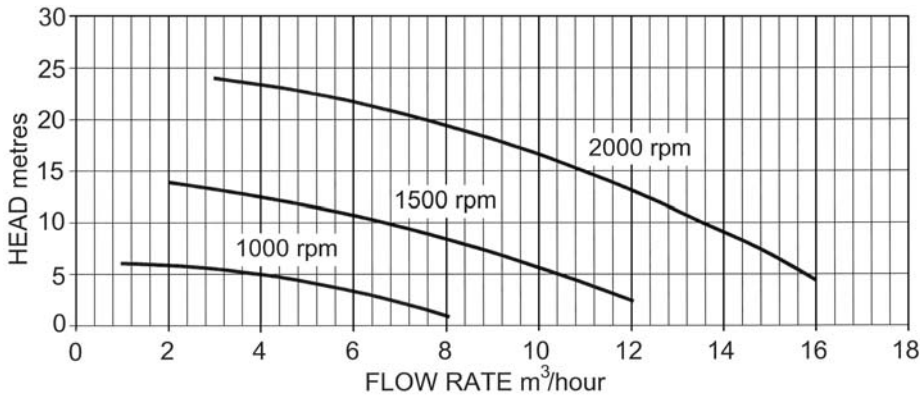

## PERFORMANCE

Model	Maximum flow rate			Maximum head	
	l/min	cu.m/hr	gall/min	metres	feet
<b>B40</b>	267	16	58	24	78

Maximum power absorbed 3.1kW at 2000rpm

## DIMENSIONS IN MM (APPROX.)

WEIGHT: 13kg

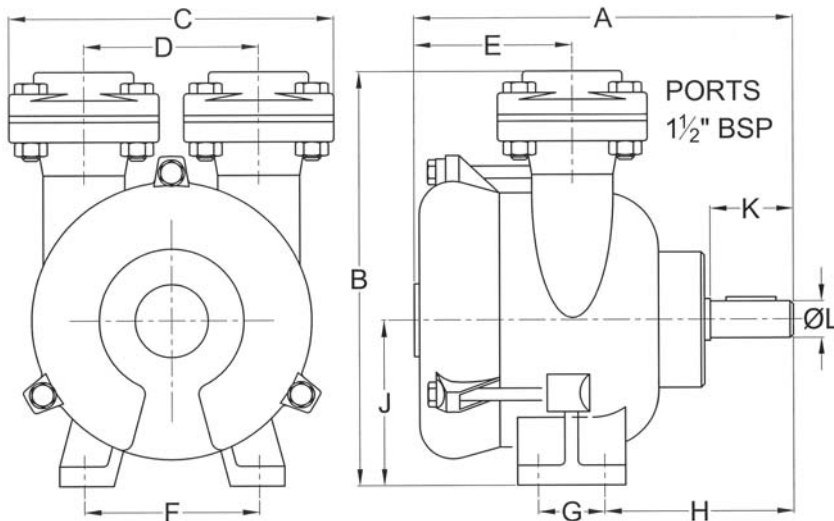

A	B	C	D	E	F	G	H	J	K	L
227.5	250	195	105	95	105	40	113.5	100	50	Ø22

## MATERIALS OF CONSTRUCTION

Pump casing	bronze
Impeller	bronze
Port counterflanges	bronze
Shaft	stainless steel AISI316
Pump head bolts	stainless steel
O-ring static seal	nitrile rubber

Pump performance and specification are subject to alteration without notice

## AVAILABLE 'A' series CLUTCHES (ask for a data sheet)

Clutch Type	Pulley Pitch Dia	Pulley Belt Section	No of Belts	FP Code
MANUAL	117mm	B	2	<b>FP-94-8030611</b>
MANUAL	140mm	B	2	<b>FP-94-8050611</b>
24v dc	152mm	SPB	1	<b>FP-94-8110427</b>
24v dc	145mm	A	2	<b>FP-94-8130427</b>

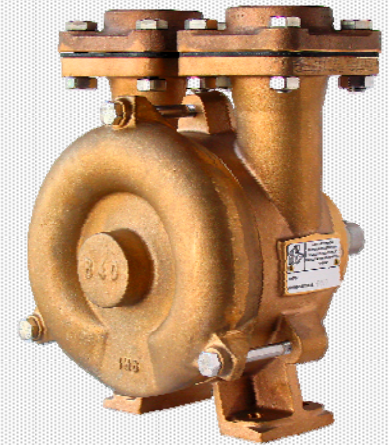

## 1 1/2" BRONZE SELF-PRIMING SIDE CHANNEL PUMP

- ◆ reliable continuous duty pump
- ◆ corrosion-resistant bronze, with stainless steel shaft
- ◆ self-priming up to 4m
- ◆ bi-directional, flow can be reversed
- ◆ carbon-ceramic mechanical shaft seal

## BRONZE PUMPS *for* SEAWATER

Cleghorn Waring  
A Division of ITT Industries Ltd  
Icknield Way  
Letchworth Garden City  
Hertfordshire • SG6 1EZ UK

Tel: +44 (0)1462 480380  
Fax: +44 (0)1462 482422  
mail@cleghorn.co.uk  
www.cleghorn.co.uk