

**PERFORMANCE**

Model	Maximum flow rate			Maximum head	
	l/min	cu.m/hr	gall/min	metres	feet
<b>AM65Z</b>	1016	61	223	57	187

Maximum power absorbed 16kW at 3000rpm

**DIMENSIONS IN MM (APPROX.)**

**WEIGHT: 93 kg**

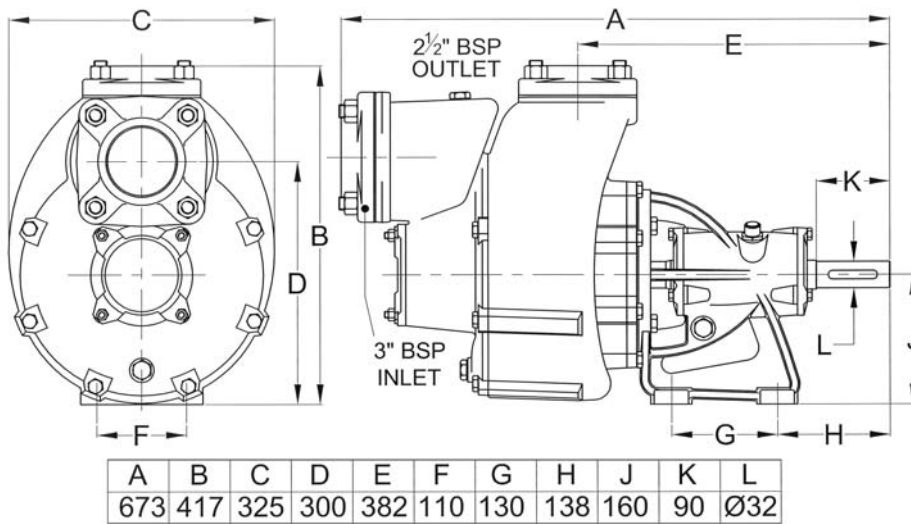

**MATERIALS OF CONSTRUCTION**

Pump casing	bronze
Impeller	bronze
Port counterflanges	Bronze
Shaft	stainless steel AISI316
Bearing housing	cast iron
Pump head bolts	stainless steel
O-ring static seal	nitrile rubber

Pump performance and specification are subject to alteration without notice

**AVAILABLE CLUTCHES** (ask for a data sheet)

Clutch Type	Pulley Pitch Dia	Pulley Belt Section	No of Belts	FP Code
MANUAL	DM35 - SPECIAL BEARING HOUSING WITH BUILT IN CLUTCH			<b>FP-94-8001011</b>
MANUAL	170mm	SPB	3	<b>FP-94-8020811</b>

# FP-series AM65D200Z

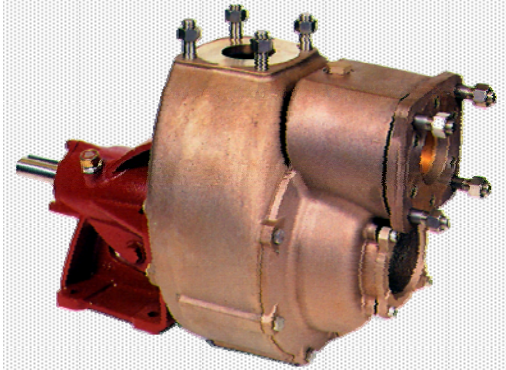

## 2 1/2" BRONZE SELF-PRIMING CENTRIFUGAL PUMP

- ◆ corrosion-resistant bronze body & impeller, with stainless steel shaft
- ◆ self-priming up to 5m
- ◆ carbon-ceramic mechanical shaft seal

## BRONZE PUMPS *for* SEAWATER

Cleghorn Waring  
A Division of ITT Industries Ltd  
Icknield Way  
Letchworth Garden City  
Hertfordshire • SG6 1EZ UK

Tel: +44 (0)1462 480380  
Fax: +44 (0)1462 482422  
mail@cleghorn.co.uk  
www.cleghorn.co.uk