

# FP-series AM50-14

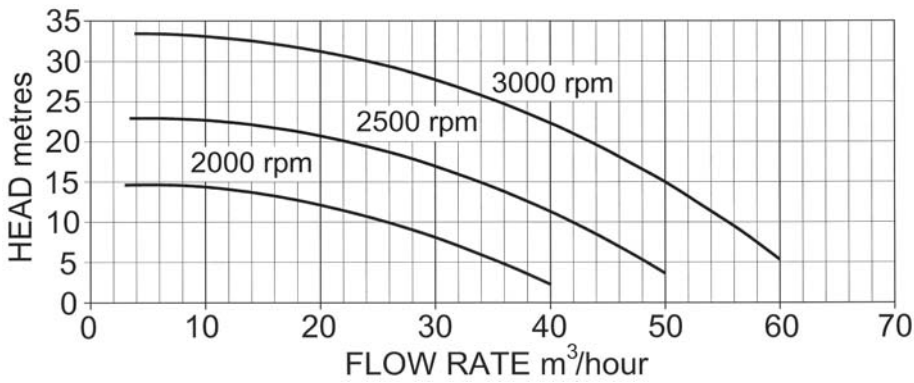

## PERFORMANCE

Model	Maximum flow rate			Maximum head	
	l/min	cu.m/hr	gall/min	metres	feet
<b>AM50-14</b>	1000	60	219	33	104

Maximum power absorbed 5.7kW at 3000rpm

## DIMENSIONS IN MM (APPROX.)

WEIGHT: 34kg

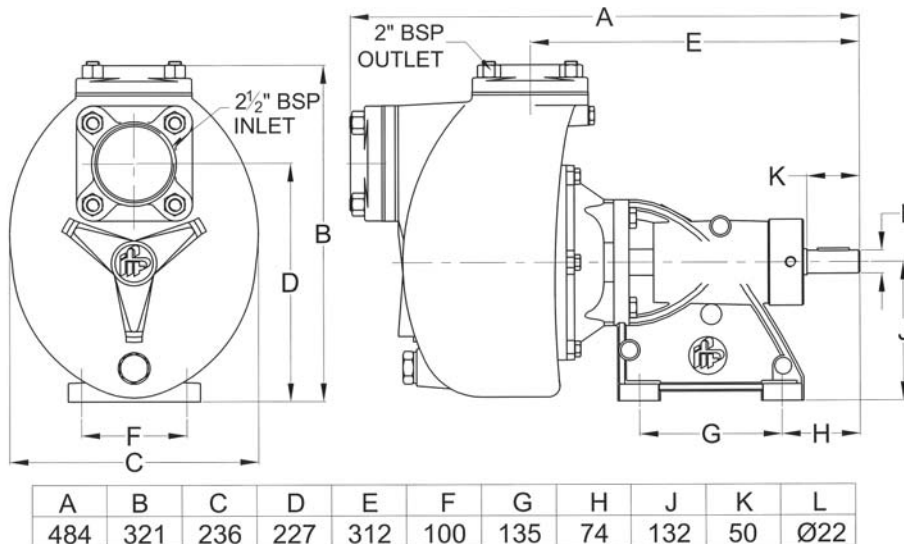

## MATERIALS OF CONSTRUCTION

Pump casing	bronze
Impeller	bronze
Port counterflanges	bronze
Shaft	stainless steel AISI316
Bearing housing	cast iron
Pump head bolts	stainless steel
O-ring static seal	nitrile rubber

Pump performance and specification are subject to alteration without notice

## AVAILABLE 'A' series CLUTCHES (ask for a data sheet)

Clutch Type	Pulley Pitch Dia	Pulley Belt Section	No of Belts	FP Code
MANUAL	117mm	B	2	<b>FP-94-8030611</b>
MANUAL	140mm	B	2	<b>FP-94-8050611</b>
24v dc	152mm	SPB	1	<b>FP-94-8110427</b>
24v dc	145mm	A	2	<b>FP-94-8130427</b>

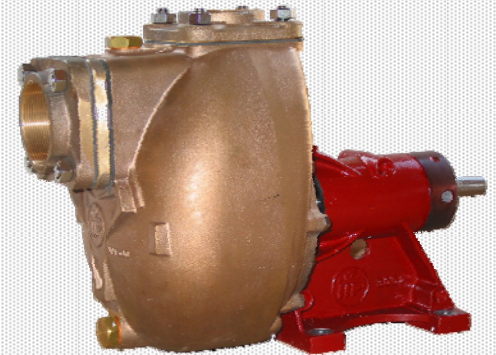

## 2" BRONZE SELF-PRIMING CENTRIFUGAL PUMP with OPEN IMPELLER



- ◆ corrosion-resistant bronze body & impeller, with stainless steel shaft
- ◆ self-priming up to 4m
- ◆ available with clockwise or anti-clockwise rotation – please specify
- ◆ carbon-ceramic mechanical shaft seal

**BRONZE  
PUMPS**  
*for*  
**SEAWATER**

Cleghorn Waring  
A Division of ITT Industries Ltd  
Icknield Way  
Letchworth Garden City  
Hertfordshire • SG6 1EZ UK

Tel: +44 (0)1462 480380  
Fax: +44 (0)1462 482422  
mail@cleghorn.co.uk  
www.cleghorn.co.uk