

FP-series AM50

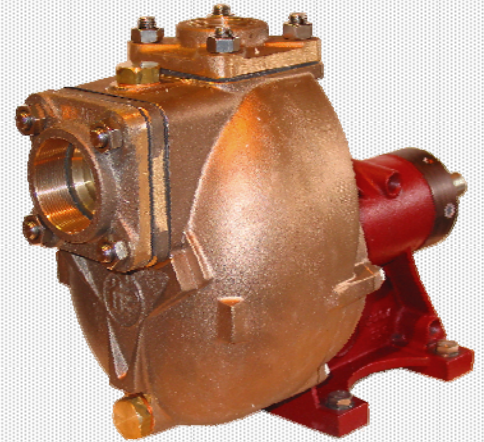

2" BRONZE SELF-PRIMING CENTRIFUGAL PUMP

- ◆ corrosion-resistant bronze body & impeller, with stainless steel shaft
- ◆ self-priming up to 4m
- ◆ available with clockwise or anti-clockwise rotation – please specify
- ◆ carbon-ceramic mechanical shaft seal

**BRONZE
PUMPS**
for
SEAWATER

Cleghorn Waring
A Division of ITT Industries Ltd
Icknield Way
Letchworth Garden City
Hertfordshire • SG6 1EZ UK

Tel: +44 (0)1462 480380
Fax: +44 (0)1462 482422
mail@cleghorn.co.uk
www.cleghorn.co.uk

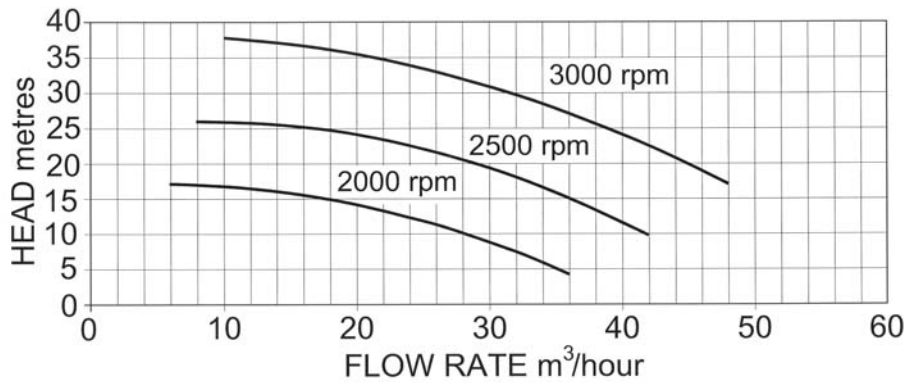

PERFORMANCE

Model	Maximum flow rate			Maximum head	
	l/min	cu.m/hr	gall/min	metres	feet
AM50	800	48	176	37	121

Maximum power absorbed 5.5kW at 3000rpm

DIMENSIONS IN MM (APPROX.)

WEIGHT: 32.2 kg

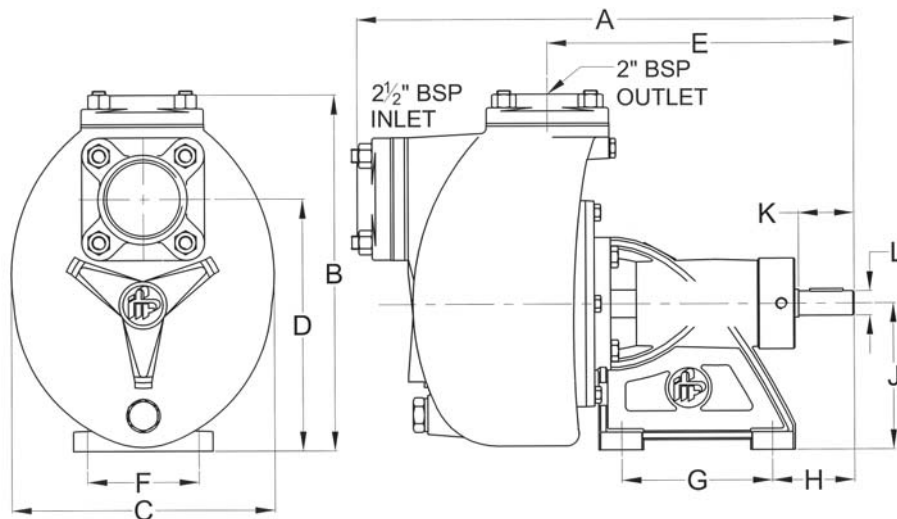

A	B	C	D	E	F	G	H	J	K	L
445	321	236	227	275	100	135	74	132	50	Ø22

MATERIALS OF CONSTRUCTION

Pump casing	bronze
Impeller	bronze
Port counterflanges	Bronze
Shaft	stainless steel AISI316
Bearing housing	cast iron
Pump head bolts	stainless steel
O-ring static seal	nitrile rubber

Pump performance and specification are subject to alteration without notice

AVAILABLE 'A' series CLUTCHES (ask for a data sheet)

Clutch Type	Pulley Pitch Dia	Pulley Belt Section	No of Belts	FP Code
MANUAL	117mm	B	2	FP-94-8030611
MANUAL	140mm	B	2	FP-94-8050611
24v dc	152mm	SPB	1	FP-94-8110427
24v dc	145mm	A	2	FP-94-8130427