

# FP-series AM40DEM2T50

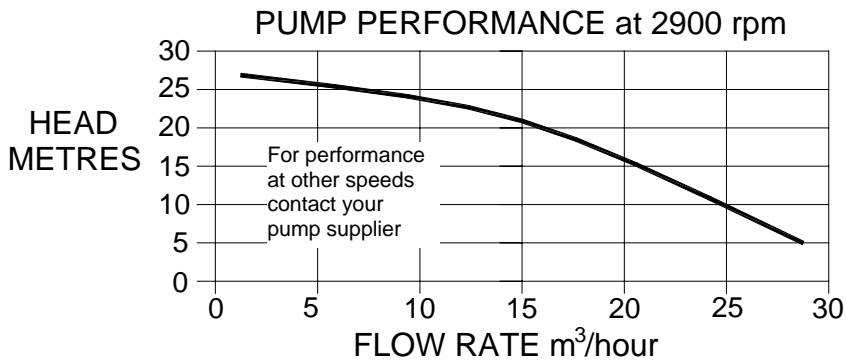

## Performance

Model	Maximum flow rate			Maximum head	
	l/min	cu.m/hr	gall/min	metres	feet
<b>AM40D EM2T50</b>	467	28	100	26	85

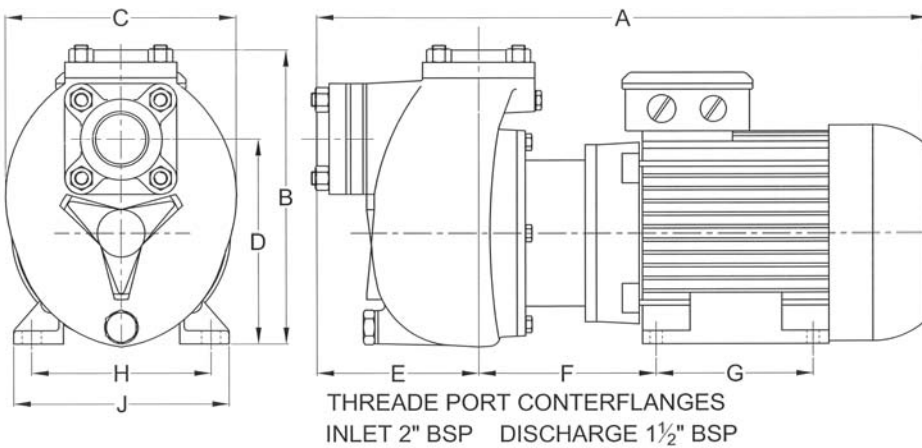

**Standard a.c. motor** 3kW 2900 rpm 400volt 3 phase 50Hz totally enclosed, fan ventilated IP55 enclosure. \*Contact your pump supplier for details of alternative motors

## Dimensions in mm (approx.)

**Weight: 44kg**

A	B	C	D	E	F	G	H	J
545	265	206	185	144	1158	140	160	192

## Materials of construction

Pump casing	bronze
Impeller	bronze
Port counterflanges	bronze
Shaft	stainless steel AISI316
Motor housing	aluminium
Pump head bolts	stainless steel
O-ring static seal	nitrile rubber

Pump performance and specification are subject to alteration without notice

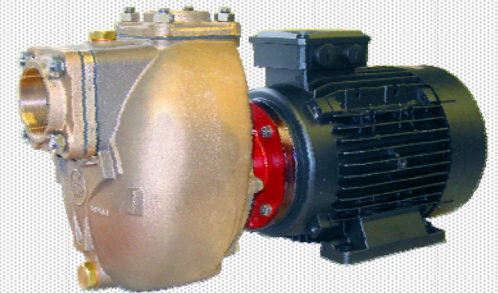

1½" BRONZE  
SELF-PRIMING  
CENTRIFUGAL PUMP  
with  
CLOSE-COUPLED  
A.C. ELECTRIC MOTOR

- ◆ corrosion-resistant bronze body & impeller, with stainless steel shaft
- ◆ self-priming up to 4m
- ◆ carbon-ceramic mechanical shaft seal

**BRONZE  
PUMPS  
for  
SEAWATER**